

REACH

ПРОФЕССИОНАЛЬНАЯ СИСТЕМА ЗВУКОУСИЛЕНИЯ

РУКОВОДСТВО ПОЛЬЗОВАТЕЛЯ



Важные инструкции техники безопасности

1. Прочтите эти инструкции.
2. Сохраните эти инструкции.
3. Соблюдайте все предостережения.
4. Следуйте инструкциям.
5. Не используйте оборудование вблизи воды.
6. Протирайте только сухой тканью.
7. Не блокируйте вентиляционные отверстия. Устанавливайте в соответствии с указаниями производителя.
8. Не устанавливайте вблизи источников тепла, таких как радиаторы, батареи отопления, обогреватели, печи и другие устройства, включая усилители мощности, которые способны излучать тепло.
9. Не пренебрегайте мерами безопасности при использовании вилки с заданным положением относительно гнезда или вилки с заземляющим контактом. Вилка с заданным положением имеет два контакта, один шире другого. Вилка с заземляющим контактом имеет два одинаковых контакта и третий заземляющий контакт. Широкий контакт или заземляющий контакт обеспечивают вашу безопасность. Если вилки поставляемые в комплекте не подходят к вашей розетке, проконсультируйтесь с электриком для замены устаревших розеток.
10. Не наступайте на кабель питания и не заземляйте его, особенно вблизи вилок, розеток и точки, где он выходит из аппарата.
11. Используйте аксессуары по спецификации производителя.
12. Используйте тележки, стойки, штативы, крепления и столы в соответствии со спецификациями производителя. При использовании тележек соблюдайте осторожность, чтобы избежать травм от опрокидывания и заваливания.
13. Отключайте оборудование из розетки во время грозы с молниями и при длительном простое.
14. Обращайтесь за сервисным обслуживанием к квалифицированным специалистам. Обращение в сервис необходимо во всех случаях когда оборудование было повреждено. Например, при повреждении обмотки или разрыва кабеля системы питания, проникновении жидкости или мелких объектов внутрь устройства, а также если оборудование находилось под дождем, не работает должным образом или упало с высоты.
15. Данное оборудование не должно устанавливаться в месте, где возможно появление капель или брызг, на оборудовании не должны размещаться емкости с водой, такие как вазы, стаканы с пивом и т.п.

16. Не перегружайте подключениями настенные розетки и удлинители, поскольку это может привести к пожару и удару электрическим током.
17. Данное оборудование имеет конструкцию Class-I и должно подключаться к источникам питания с использованием защитного заземляющего контакта.
18. Данное оборудование оснащено тумблером AC системы питания. Тумблер находится на задней панели и должен всегда оставаться доступен пользователю.
19. Сетевая вилка предназначена для полного отключения устройства, возможность полностью обесточить оборудование должна быть постоянно доступна.
20. ЗАМЕЧАНИЕ: Данное оборудование было протестировано в соответствии с требованиями части 15 правил FCC для цифровых устройств Class B. Соответствие данным требованиям обеспечивает безопасное функционирование оборудования в жилых помещениях. Данное оборудование генерирует, использует и может излучать радиочастоты, и при установке с нарушением инструкций может стать причиной появления радио помех. Как бы то ни было, правильная установка не гарантирует полное отсутствие радио помех. Если оборудование оказывает негативное влияние на прием радио и теле сигналов, что определяется простым выключением устройства, вы можете воспользоваться одной из следующих мер:
 - Перенаправьте антенну или измените ее положение.
 - Увеличьте расстояние между оборудованием и приемником.
 - Подключите оборудование и приемник в различные сетевые розетки.
 - Проконсультируйтесь с опытным техником в сфере радио/телевидения.
21. Данное оборудование не превышает пределов излучения радиопомех для цифровых устройств Class A/Class B (в зависимости от того, какая из категорий применима) в соответствии с правилами по радиопомехам Канадского департамента связи.
22. Воздействие чрезвычайно высоких уровней шума может привести к потере слуха. Люди различаются по своей восприимчивости и возможности потерять слух из-за шумов. Но при длительном воздействии интенсивного шума опасность потерять слух сохраняется для всех без исключения. Администрация правительства США по безопасности и гигиене определяет допустимые уровни шума, указанные в таблице ниже. В соответствии с этими данными, шумы превышающие указанные уровни могут привести к потере слуха. Во избежание травм, вызванных высокими уровнями звукового давления, при работе с оборудованием рекомендуется использовать такие средства защиты, как беруши и звукоизоляционные наушники.





ОПАСНОСТЬ УДАРА ЭЛЕКТРИЧЕСКИМ ТОКОМ!

НЕ ОТКРЫВАТЬ!



ВНИМАНИЕ: ВО ИЗБЕЖАНИЕ УДАРА ЭЛЕКТРИЧЕСКИМ ТОКОМ НЕ ОТКРЫВАЙТЕ КОРПУС ОБОРУДОВАНИЯ. ВНУТРИ НЕТ ДЕТАЛЕЙ ДЛЯ ОБСЛУЖИВАНИЯ ПОЛЬЗОВАТЕЛЕМ. ВЫПОЛНЯТЬ СЕРВИСНЫЕ ОПЕРАЦИИ ДОЛЖЕН КВАЛИФИЦИРОВАННЫЙ ПЕРСОНАЛ.

 Символ молнии внутри треугольника обозначает угрозу, связанную с присутствием тока и опасного уровня напряжения внутри устройства, способного привести к удару электрическим током.

 Восклицательный знак внутри треугольника предупреждает о наличии в тексте важных инструкций, связанных с обслуживанием или использованием оборудования.

DL32R имеет два вентилятора на задней панели для охлаждения. Поток воздуха протекает через боковые и наклонную верхнюю части корпуса, выходя через отверстия задней панели. Всегда оставляйте не менее 10 см пространства сзади и не менее 2 см по бокам устройства.

При установке в рэк, задняя панель рэка должна оставаться открытой с запасом не менее 10 см между задней частью рэка и ближайшей стеной (при зазоре между боковыми поверхностями устройства и рэка не менее 2 см). Для рэков с вентиляцией только через переднюю панель следует оставлять хотя бы по одному рэковому пространству сверху и снизу устройства (при зазоре не менее 2 см с внутренними боковыми стенками рэка и не менее 4 см позади устройства).

 **Правильная утилизация изделия:** Данный символ обозначает необходимость утилизации отдельно от прочего домашнего мусора в соответствии с директивой WEEE (2012/19/EU) и национальным законодательством страны использования. Устройство должно быть передано в авторизованный центр переработки электрического и электронного оборудования. Некорректное обращение с такого рода мусором может привести негативному воздействию на окружающую среду и здоровье человека, поскольку содержит опасные вещества, присущие всем видам электрического и электронного оборудования. Вместе с тем, выполняя корректную утилизацию, вы вносите свой вклад в защиту окружающей среды. Для более подробной информации о том, где и как вы могли бы провести утилизацию оборудования, пожалуйста, обратитесь в компетентные органы государственной власти или сервисные компании осуществляющие сбор и переработку мусора.

Длительность в часах	Звуковой уровень дБА, медленный отклик	Пример
8	90	Дуэт в маленьком клубе
6	92	
4	95	Поезд метро
3	97	
2	100	Очень громкая академическая музыка
1.5	102	
1	105	Оружие друг на друга супруги
0.5	110	
0.25 и менее	115	Наиболее громкая часть рок концерта

ОСТОРОЖНО — Во избежание удара электрическим током, не оставляйте оборудование под воздействием влаги.

Содержание

Важные инструкции техники безопасности	2	Расположение	16
Содержание	3	Акустика комнаты	16
Особенности	4	Защита.....	17
Введение	5	Лимитер	17
Использование руководства.....	5	Защита от разрушения излучателя	17
Предостережения	5	Защита от перегрева	17
Начало работы	5	Питание	17
Схемы подключения	6	Уход и обслуживание	17
Приложение Mackie Connect	8	Приложение А: Сервисная информация	18
Reach: особенности задней панели	11	Приложение В: Техническая информация	19
1. Разъем системы питания	11	Габариты Reach	21
2. Выключатель	11	Частотная характеристика Reach	22
3. Входы XLR и 1/4" Combo	11	Блок-схема Reach	23
4. Индикаторы перегрузки	12	Приложение С: Таблица с пресетами эффектов ...	24
5. Вход Bluetooth / Aux In.....	12	Гарантия	25
6. Наушники	12		
7. Разъем для напольного переключателя	12		
8. Разъемы для линкования	12		
Reach: особенности боковой панели	13		
9. Индикатор уровня	13		
10. Кнопки Ch 1-4	13		
11. Кнопка BT / Aux	13		
12. Кнопка Mon	13		
13. Кнопка Main	13		
14. Выключение подсветки логотипа	14		
15. Регулятор уровня	14		
16. Подавитель обратной связи	14		
17. Процессор эффектов	14		
18. Режимы эквалайзера	14		
19. Кнопка Side	15		
20. Домашняя уборка [Кнопки HW1 и HW2] ...	15		
Сброс до заводских настроек.....	15		

Пожалуйста, впишите здесь серийный номер вашего устройства (для оформления страховых случаев, технической поддержки, авторизации при возврате, чтобы потешить папину гордость и т.п.)

Продавец:

Дата покупки:



Ставьте лайки



Подписывайтесь



Смотрите наши видео

Особенности

Специализированное решение - портативной системы звукоусиления "Все-в-одном"

- Профессиональная система звукоусиления 720 Вт с ультра широкой площадью покрытия, возможностью персонального мониторинга, беспроводным управлением и передачей аудио по Bluetooth
- Технология Mackie ARC™ (Amplified Radial Curve) заключается в уникальном расположении массива излучателей и структуре волновода, обеспечивающих горизонтальную дисперию 150 градусов, которая позволит охватить всю аудиторию
 - Три 1" купольных компрессионных высокочастотный драйвера
 - Два 6.5" высокопроизводительных динамика для воспроизведения средних и низких частот
- Возможность персонального мониторинга с системой Mackie EarShot™, благодаря которой исполнители будут лучше слышать себя на сцене
 - Дополнительные встроенные громкоговорители с независимым регулятором громкости для расширения возможностей мониторинга
 - Дополнительные громкоговорители на каждой боковой стороне Reach обеспечат мониторинг, выполняя функции "прострелов"
 - Также представляет собой великолепную возможность для расширенного угла горизонтального раскрытия акустической системы (до 250 градусов)
- Беспроводной управление, передача аудио по Bluetooth и встроенный 6-канальный цифровой микшер
 - Полнофункциональное беспроводное управление микшером с помощью приложения Mackie Connect™ для iOS¹ и Android² устройств
 - Поточковая передача аудио по Bluetooth® с возможностью интеграции в ваш микс
 - Все необходимые возможности для подключения небольшой группы, сольного исполнителя или презентатора
 - 4 входа XLR combo для вокальных микрофонов, гитар, клавишных и т.д.
 - Дополнительный вход 1/8" для воспроизведения музыки с ноутбука и других устройств
 - Выход на наушники 1/4" и возможность тихих репетиций
 - Разъем для подключения напольного переключателя и контроль включения эффектов
 - Выход для линкования нескольких систем Reach для создания более производительной системы
 - Профессиональные инструменты для настройки звука
 - 16 цифровых эффектов (ревербераторы, задержки и т.д.) с отличным качеством звучания
 - 3-полосный эквалайзер на каждом канале для управления тембром
 - Выступление без лишних опасений со встроенным подавителем обратной связи
 - Разнообразные пресеты звучания для наилучшего качества в любых условиях
 - 3 пользовательских пресета для быстрой настройки системы
 - Интуитивно понятное управление непосредственно на оборудовании содержит все основные функции для сведения, без необходимости использования смартфона
- Прочная сумка для транспортировки и хранения (продается отдельно)

¹ Требуется iOS 8.0 или более поздние версии. Поддерживает iPhone 6S Plus, iPhone 6S, iPhone 6 Plus, iPhone 6, iPhone 5S, iPhone 5C, iPhone 5, iPad (4-ое поколение), iPad (3-е поколение), iPad 2, iPad Air 2, iPad Air, iPad mini 4, iPad mini 3, iPad mini 2 и iPad mini, iPod Touch (5-е поколение).

² официально поддерживает версии Android 4.1-4.4, 5.0 и старше. Официально поддерживаемые/рекомендуемые устройства: Google Nexus 6, Samsung Galaxy S6, Samsung Galaxy S5, Samsung S5 Mini, Samsung S4 Mini, Samsung Note 4, Samsung Note 3, LG G Flex, LG G3, HTC One M9, HTC One M8, Moto G, Moto E, Sony Xperia Z3.

Прочие устройства Android официально не поддерживаются, но ожидаемо их корректное функционирование to function as desired. iPhone and iPod are registered trademarks of Apple Inc., registered in the U.S. and other countries.

Android является торговой маркой Google Inc.

Введение

Reach™ это специализированное решение для звукоусиления "Все-в-одном". Передовая технология ARC™ (Amplified Radial Curve) обеспечивает покрытие аудитории слушателей с высокой точностью, а встроенная система EarShot™ расширяет функционал Reach™, добавляя возможности сценического мониторинга. Плюс, беспроводная передача аудио и управление встроенным 6-канальным цифровым микшером с помощью iOS и Android приложения Mackie Connect™ приносит вам свободу удаленного управления уровнями сигналов, эквалайзером и всеми инструментами, включая подавитель обратной связи, для достижения удивительного качества звука в любом окружении.

Использование руководства:

Раздел "Начало работы", расположенный далее, поможет вам быстро начать работу. Раздел со схемами подключений содержит несколько наиболее типичных систем, а оставшиеся разделы более детально описывают технические особенности Reach.



Данный знак свидетельствует о наличии важных замечаний о работе с ProDX. Обязательно прочитайте и примите к действию данные инструкции.

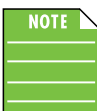

Данный знак обращает ваше внимание на наличие свойств или функций связанных с использованием ProDX.

Предостережения:

- Не слушайте громкую музыку в течение продолжительных периодов времени. Пожалуйста, обратите внимание на инструкции по технике безопасности на странице 2, относящиеся к защите слуха.
- В общем случае, система Reach должна быть включена в последнюю очередь, после используемых в цепи микшеров и источников сигнала. А также должна быть выключена первой. Все это позволит исключить появление шумов и всплесков в трансляции при включении/выключении устройств.
- Сохраните коробку и упаковочные материалы! Они могут понадобиться вам в будущем. Более того, кошки обожают играть с ними, неожиданно выпрыгивать из коробки, как из укрытия. Всегда делайте вид, будто вы этому удивлены!
- Сохраните ваш чек, подтверждающий покупку в надежном месте.

Getting Started

Описанные далее шаги позволят вам провести быструю установку Reach.



Описанные ниже процедуры касаются только установки оборудования. После выполнения этих действий, необходимо установить подключение к Reach с помощью вашего смартфона и начать настройку с помощью приложения MixerConnect (см. подробнее на странице 11).

1. Выполните всю необходимую коммутацию при выключенном оборудовании.
2. Подключите к Reach источники сигнала, такие как:
 - Микрофоны к микрофонным входам
 - Источники с инструментальным уровнем, такие как акустические гитары с активным звукоснимателем к инструментальным входам
 - Источники с линейным уровнем сигнала, такие как клавишные инструменты, драм машины, MP3 проигрыватели к линейным входам
 - Медиа источники, такие как смартфон могут быть подключены через Bluetooth.
3. Подключите кабель системы питания к соответствующему IEC разъему микшера и сетевой розетке.
4. Включите Reach.
5. Убедитесь, что уровень громкости установлен корректно. Выберите входной канал, нажав на соответствующую кнопку канала и убедитесь, что выполнена настройка приблизительно на половину от максимально возможного уровня. Выполните корректировку настройки при необходимости.
6. Медленно выведите выходной уровень для комфортного прослушивания, выбрав основной выход с помощью кнопки на передней панели и поворачивая ручку вправо.
7. Прочтите оставшиеся разделы руководства а также руководство по MixerConnect для получения более подробной информации.

Схемы подключения

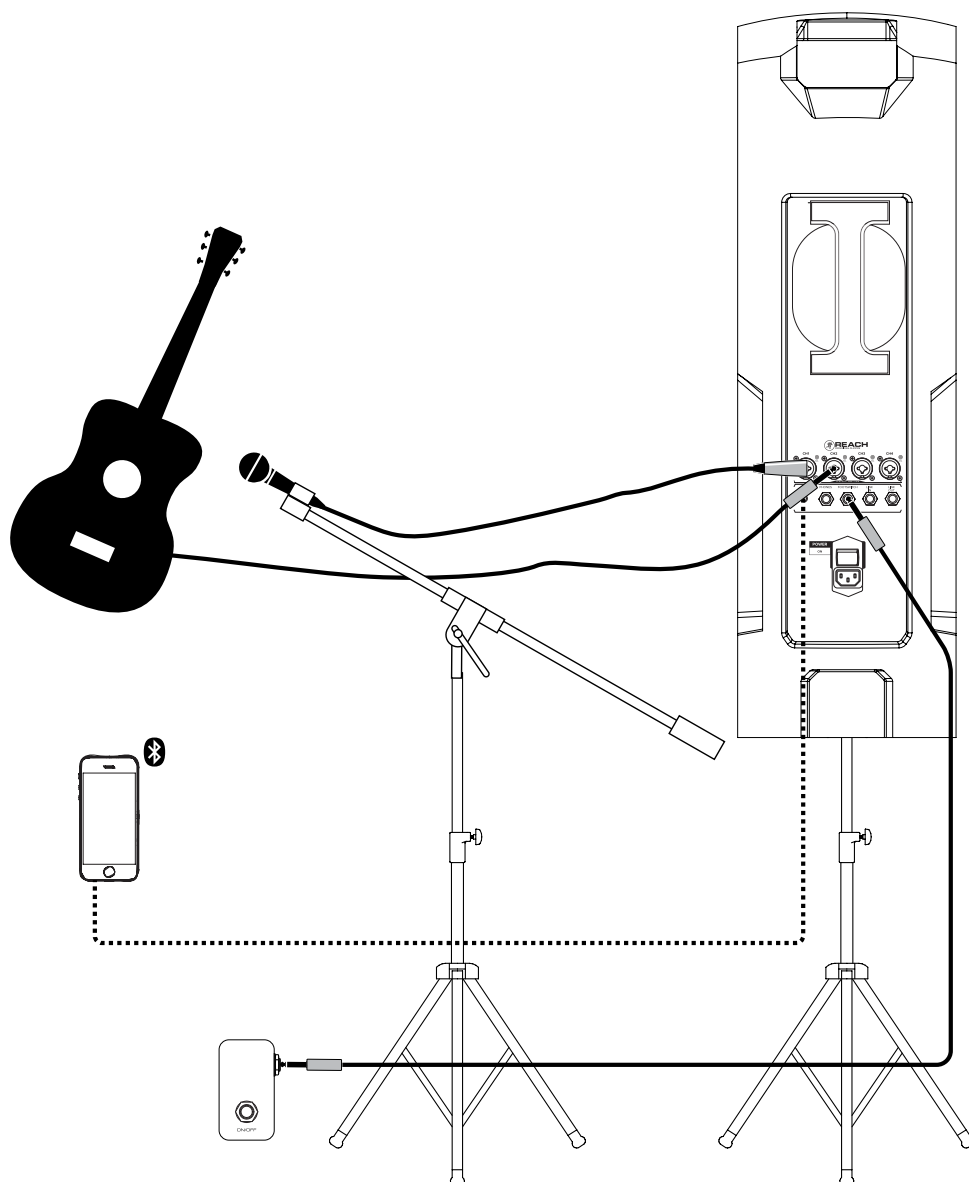

Reach представляет собой превосходную систему для солирующих авторов-исполнителей, кто нуждается в портативной готовой к работе системе звукоусиления, которую легко взять с собой в кофейню, в акустическую, небольшие арендованные пространства.

Кроме Reach вам может понадобиться акустическая гитара, микрофон, сигнальные кабели и кабели системы питания. Не забудьте о смартфоне! С его помощью вы объявите о датах вашего турне в социальных сетях. И что более важно, подключив его к Reach по Bluetooth или через вход 1/8", сможете устроить jam сессию под сопровождающий трек с вашего устройства, а также сможете управлять настройками Reach в приложении MixerConnect.

В данном примере микрофон подключен к первому каналу (channel 1). Настройте уровень как описано на странице 14. Теперь подключите вашу гитару ко второму каналу (channel 2). Настройте уровень сигнала гитары. Вы можете сделать звучание более красочным, используя эффекты. Нажмите и удерживайте кнопку канала, для которого вы хотели бы добавить эффект, и продолжите настройку, изменяя уровня эффекта на ваш вкус. Более подробная информация указана на страницах 13-14.

Если вы захотите применить к выходному сигналу эквалайзер, данная процедура детально описана на странице 14. Для приведенной схемы подключения идеальным пресетом будет solo. Корректный контроль низких частот и яркий сверкающий "верх". Дополнительно, вы можете использовать подавитель обратной связи [страница 14], и он автоматически предотвратит ее появление во время вашего выступления.

Сольное выступление

Схемы подключения (продолжение)



Схема для акустического дуэта аналогична схеме для одного солиста, за исключением того, что теперь добавляется дополнительная гитара и микрофон, подключенные к каналам 3 и 4.

Как и в предыдущем случае, вам могут понадобиться акустические гитары, микрофоны, сигнальные кабели, кабели системы питания и смартфон для подключения к Reach по Bluetooth (или через входной разъем 1/8").

Настройте уровни гитар и микрофонов, как описано на странице 14. Вы можете сделать звучание более красочным, используя эффекты. Нажмите и удерживайте кнопку канала, для которого вы хотели бы добавить эффект, и продолжите настройку, изменяя уровня эффекта на ваш вкус. Более подробная информация указана на страницах 13-14.

Для приведенной схемы подключения идеальным пресетом будет solo. Корректный контроль низких частот и яркий сверкающий "верх". Дополнительно, вы можете использовать подавитель обратной связи [страница 14], и он автоматически предотвратит ее появление во время вашего выступления.

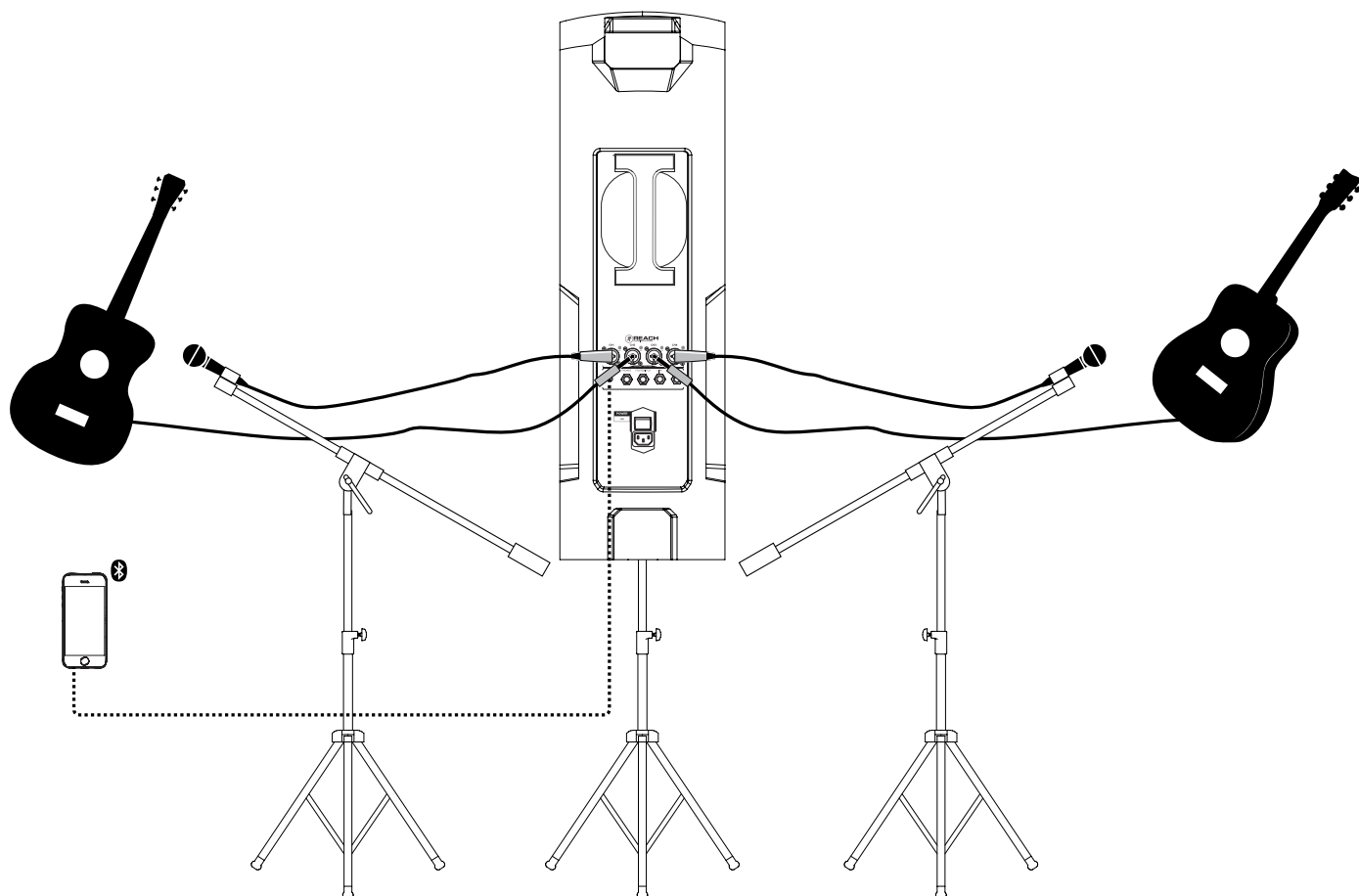

Hookup Diagrams continued...

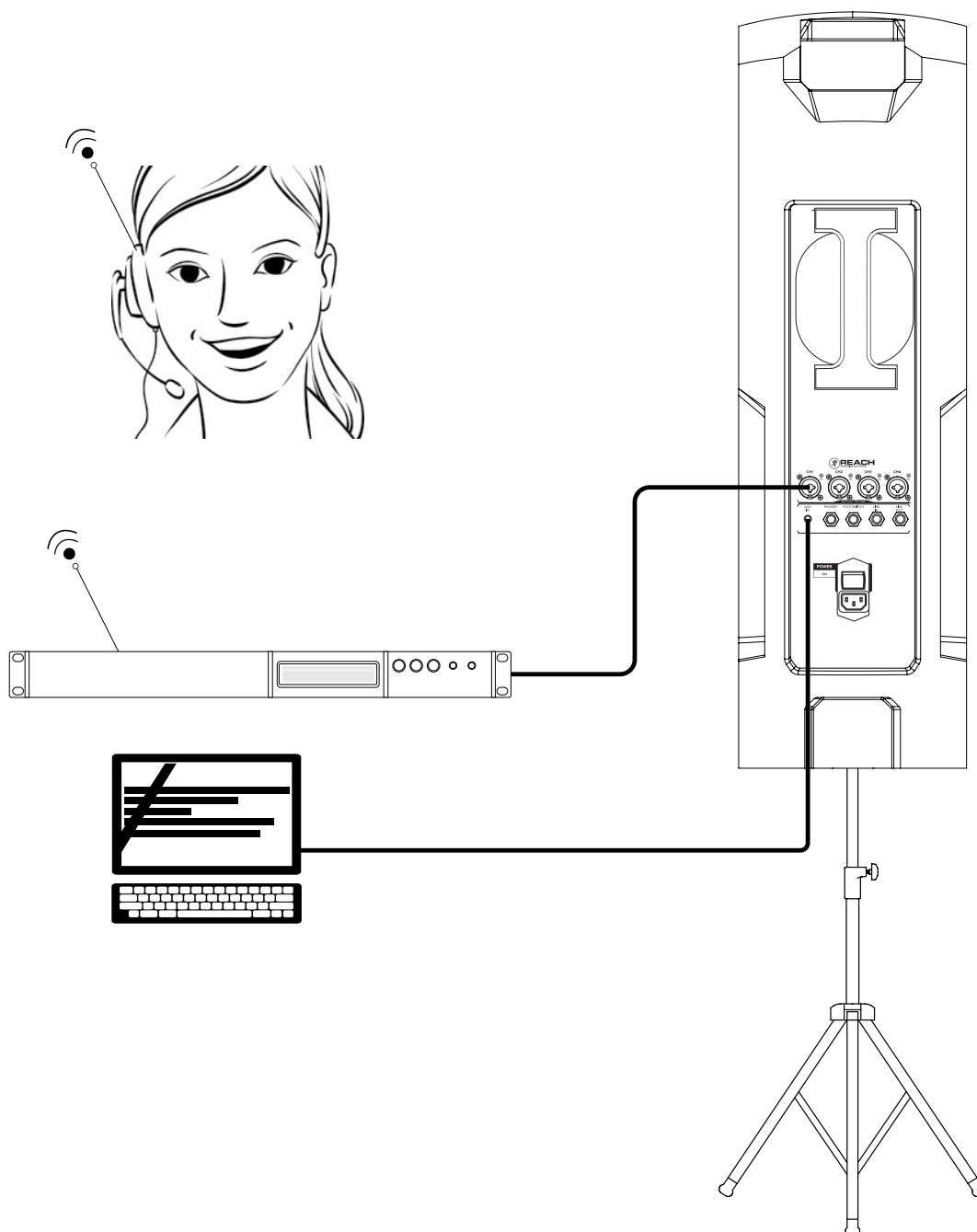

Reach is the perfect sound system for presentations, as well! Here, the presenter connected her wireless headset to the Reach, allowing her to wander the stage and work the audience, presenting all of the benefits of Reach simultaneously.

Additionally, a laptop is connected to the aux input for the stereo audio / video portion of the presentation. Be sure to adjust the levels as described on page 14.

For the output, you will want to set an EQ mode, described in detail on page 14. Because speech is the primary audio source, the voice EQ mode works well. It provides clear and precise intelligibility by featuring a low frequency roll-off to get rid of unwanted thumps. Additionally, it adds boost and sparkle to the mid-range and high frequencies which is critical for speech applications.

Presenter Setup

Hookup Diagrams continued...

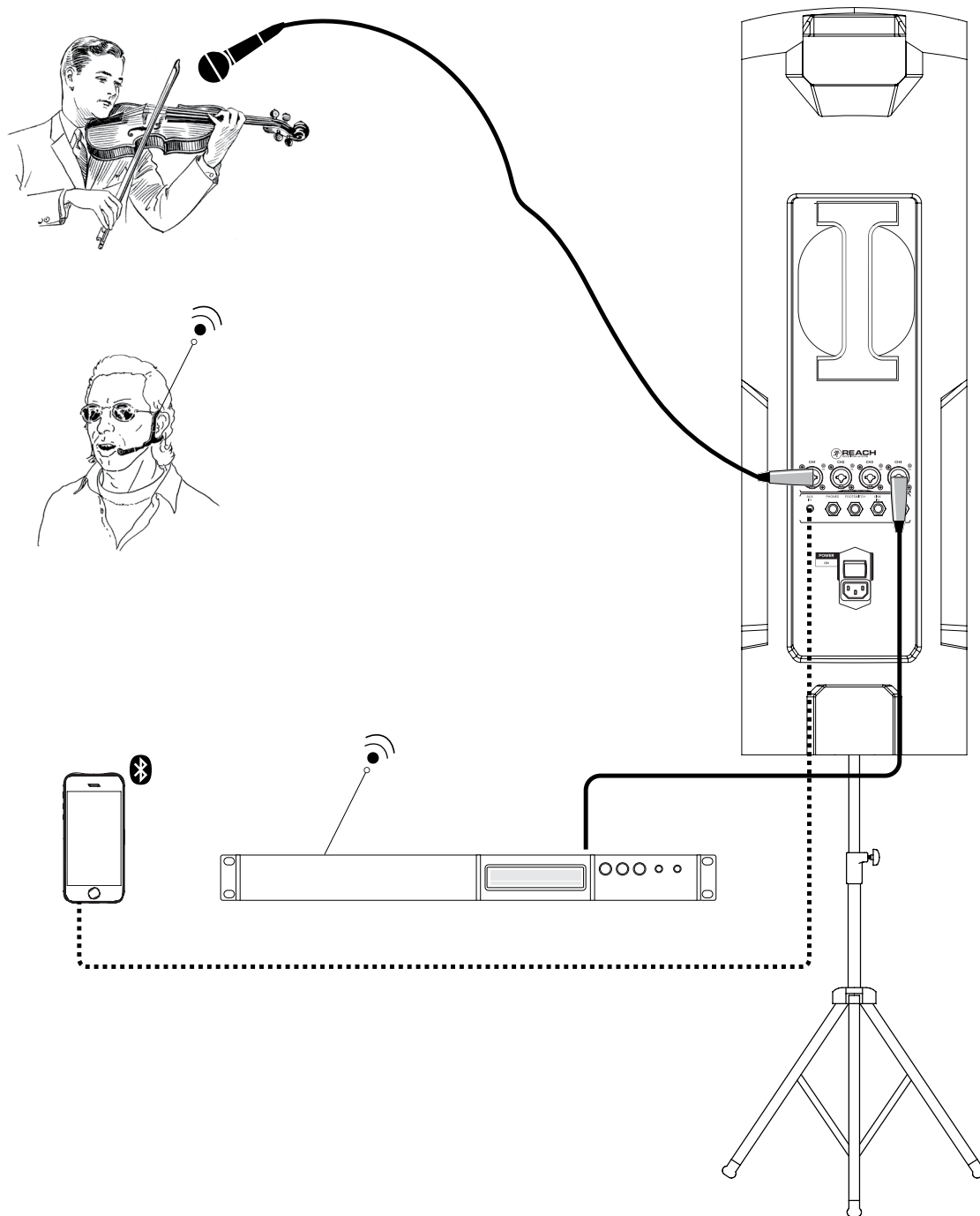

Are you in need of a portable, all-in-one sound system for a wedding ceremony? Reach is the answer! Here, the mic'd violinist [Ch. 1 input] is playing the entry procession music. Next up is the wedding officiate who is utilizing a wireless mic with the wireless receiver connected to the channel 4 input. A device is connected to Reach via Bluetooth (or 1/8" input) playing music as the wedding party and guests leave the premises. Be sure to adjust all levels as described on page 14.

Guess what? Reach can now be used at the wedding reception, too!

For the output, you will want to set an EQ mode, described in detail on page 14. Solo mode works well for the violinist, voice EQ mode for the officiating, then back to solo mode for the exit procession music. Finally, you will want to set Reach to the DJ EQ mode for the reception.

Don't forget to utilize Reach's feedback destroyer [page 14] to automatically kill any feedback.

Wedding Ceremony Setup

Reach: Rear Panel Features

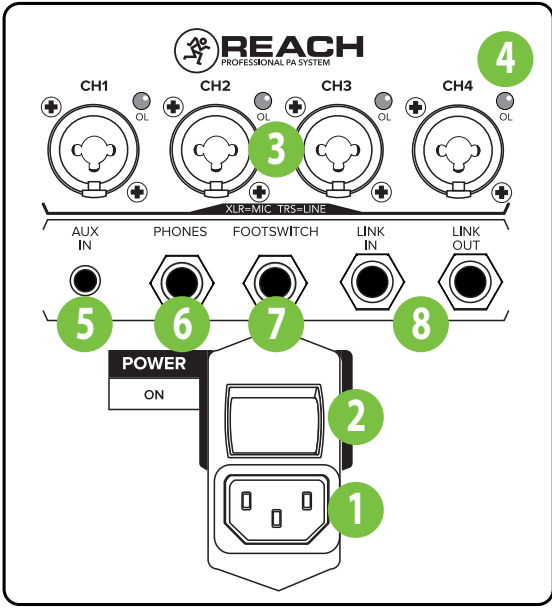

Mackie Connect App

Reach is designed to be used in conjunction with the Mackie Connect App. With it, all of the hardware features listed here – and more! – may be controlled remotely via Bluetooth connection. The only thing the Mackie Connect App can't do is turn the unit on and off or pair a Bluetooth device.

More information about the Mackie Connect App may be found by visiting the Mackie Connect App Reference Guide.

1. Power Connector

This is a standard 3-prong IEC power connector. Connect the detachable linecord (included in the box) to the power receptacle, and plug the other end of the linecord into an AC outlet. .



Warning: Disconnecting the plug's ground pin is dangerous. Don't do it.

2. Power Switch

Press the top of this rocker switch inwards to turn on. The front panel Running Man logo will glow with happiness...or at least it will if Reach is plugged into a suitable live AC mains supply.

Press the bottom of this rocker switch inwards to put Reach into standby mode. It will not function, but some circuits are still live. To remove AC power, either turn off the AC mains supply, or unplug the power cord from Reach and the AC mains supply.

3. XLR and 1/4" Combo Inputs The four input channels may accept a balanced mic signal using an XLR connector. They are wired as follows, according to standards specified by the AES (Audio Engineering Society).

XLR Balanced Wiring:

Pin 1 = Shield (ground)
Pin 2 = Positive (+ or hot)
Pin 3 = Negative (- or cold)

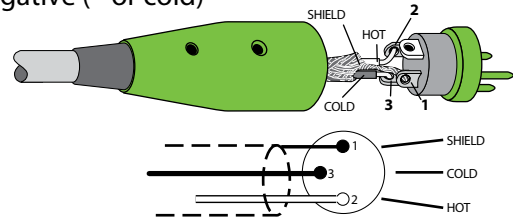

In addition to accepting a balanced mic signal using an XLR connector, these input channels may also accept 1/4" line-level signals driven by balanced or unbalanced sources.

Additionally, all four input channels may accept Hi-Z sources (such as guitars) via the 1/4" input without the need for a separate DI box.

To connect balanced lines to these inputs, use a 1/4" Tip-Ring-Sleeve (TRS) plug. "TRS" stands for Tip-Ring-Sleeve, the three connection points available on a stereo 1/4" or balanced phone jack or plug. TRS jacks and plugs are used for balanced signals and are wired as follows:

1/4" TRS Balanced Mono Wiring:

Sleeve = Shield
Tip = Hot (+)
Ring = Cold (-)

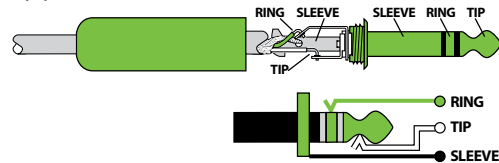

To connect unbalanced lines to these inputs, use a 1/4" mono (TS) phone plug, wired as follows:

1/4" TS Unbalanced Mono Wiring:

Sleeve = Shield
Tip = Hot (+)

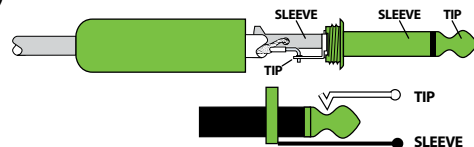

NEVER connect the output of an amplifier directly to a Reach's input jack. This could damage the input circuitry!

Reach: Rear Panel Features continued...

4. OL LEDs

This LED will illuminate red when the input signal is too high, indicating a signal overload. This should be avoided, as distortion will occur.

If the OL LED comes on regularly, check that the level is set correctly for the input device. The signal is at -2 dBu before hard clip begins.

5. Bluetooth / Aux In

The Bluetooth / Aux input channel may accept a 1/8" line level or Bluetooth [stereo audio streaming] signal from a smartphone, MP3 player, or other signal source. This input level may be raised or lowered via Reach's endless rotary level knob or Mackie Connect.



The Bluetooth may disconnect when affected by Electrostatic Discharge [ESD] or electrical fast transients (EFT). If this occurs, manually reconnect the Bluetooth connection.



NEVER connect the output of an amplifier directly to a Reach's input jack. This could damage the input circuitry.



A Bluetooth connection and 1/8" line-level connection may NOT be used simultaneously. If there is a physical aux input, it will take priority over any Bluetooth connection. For example, if you are playing a song from a device (connected via Bluetooth) and connect an MP3 player to the 1/8" jack, the device's song will be interrupted and the MP3 player now takes precedence.

6. Phones

This 1/4" TRS connector supplies the output to stereo headphones. Headphones are selected with the Main button and the level may be adjusted with the endless rotary knob. By default, all speakers are muted when headphones are plugged in, but this may be changed via the Mackie Connect app.

The phones output follows standard conventions:

- Tip = Left channel
- Ring = Right channel
- Sleeve = Common ground



WARNING: The headphone amp is loud and can cause permanent hearing damage. Even intermediate levels may be painful to the ears. BE CAREFUL! Always turn the phones level control all the way down before connecting headphones or pressing a solo switch, or doing anything new that may affect the headphone volume. Then turn it up slowly as you listen carefully.

7. FX Footswitch

This 1/4" TRS connector is where to connect your favorite footswitch. This allows you to easily mute or un-mute the internal effects at will. Reach accepts a latching footswitch by default. This is a typical guitar channel switch, for example. Momentary switches may be used instead, but you will need to change the footswitch type via the Mackie Connect app.

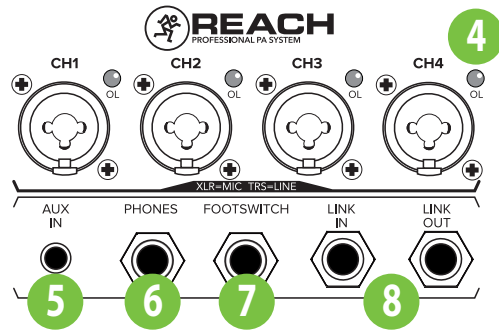

8. Link In / Link Out

Link out provides a mono sum of channels 1-4 and the right only of the Bluetooth / Aux and FX, creating a nice stereo PA system for linked units.

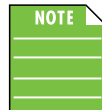

Ideally, the link out jack will be connected to the link in jack of another Reach, but the link out jack may be connected to the input jack of a

powered loudspeaker or subwoofer. These signals are post main fader, meaning that devices fed by the link in / out will experience the same volume changes that Reach does (whether controlled from the hardware interface, or from the Mackie Connect app.)

See the hookup diagram on page 8 for an example of the Link I/O.

Reach: Side Panel Features

9. LED Indicator

The 15-segment bi-color LED ladder is used to gauge the input, FX and output level settings, as well as the main output metering.

These LEDs illuminate to indicate the level of the currently selected input or output level [white for channel level setting and green for FX send level setting].

This is easily changed by selecting the input or output level you want to update followed by turning the level knob up (clockwise) or down (counter-clockwise).

If you are simply metering – after 5-second timeout to Main – they will reflect output metering.

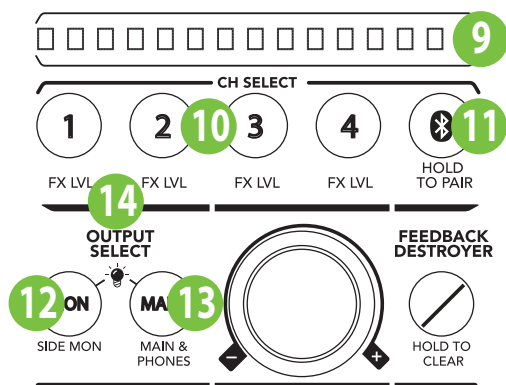

10. Ch 1-4 Buttons

Press a channel button to select it. It will illuminate white when selected. Once a channel is selected, be sure to raise or lower that channel's input level using the endless rotary level knob. The input level will be represented in the meters with white LEDs. After five seconds of inactivity, the selection changes back to the default "Main".

Press and hold a channel button to select and adjust that channel's FX send level. It will illuminate green when selected. Once a channel is selected, be sure to raise or lower that channel's FX send level using the endless rotary level knob. The FX send level will be represented in the meters with green LEDs. After five seconds of inactivity, the selection changes back to the default "Main".

11. BT / Aux

Press the BT / Aux button to select it. It will illuminate white when selected (whether a device is paired or not). Once selected, be sure to raise or lower the Bluetooth/Aux input level using the endless rotary level knob or Mackie Connect. The input level will be represented in the meters with white LEDs. After five seconds of inactivity, the selection changes back to the default "Main".



To enter pairing mode, press and hold the BT / Aux button. The button LED will illuminate and flash white while in mode. While Reach is in pairing mode, simultaneously scan for Bluetooth devices on your device. You should see Reach appear in the "available devices" list. From the "available devices" list, indicate that it is successfully connected. If it does not, start the pairing process again, and make sure that Reach and your device are both in pairing mode at the same time.



The Bluetooth may disconnect when affected by Electrostatic Discharge [ESD] or electrical fast transients (EFT). If this occurs, manually reconnect the Bluetooth connection.

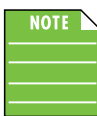

If no device is paired and a smart phone or MP3 player is plugged into the aux input, the Bluetooth channel controls the level for this input.

12. Mon Button

Press the Mon button to select it. It will illuminate white when selected. Once mon is selected, be sure to raise or lower the selected mon output level using the endless rotary level knob or Mackie Connect. The mon output level will be represented in the meters with white LEDs.

The side monitor speakers may be selected by pressing the mon button [19].

The main button is the default, so it will revert back to main after five seconds of inactivity.

13. Main Button

Press the Main button to select it. It will illuminate white when selected. Once main is selected, be sure to raise or lower the main / phones output level using the endless rotary level knob or Mackie Connect. The main / phones output level will be represented in the meters with white LEDs.

The main button is the default, so if any other button has been selected, it will revert back to main after five seconds of inactivity.

Reach: Side Panel Features continued...

14. Running Man Logo On / Off

The Running Man logo on the front of the Reach illuminates when the “Mon” and “Main” buttons are pressed simultaneously. Follow the same steps to turn the logo off.

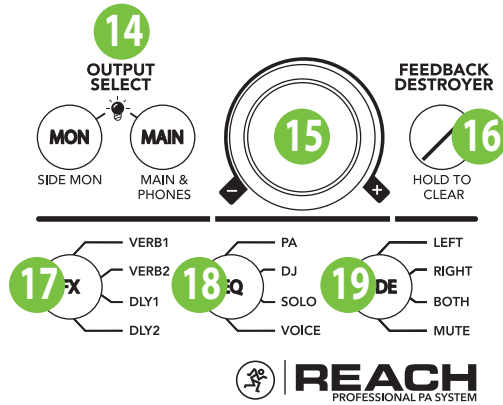

15. Level

This endless rotary knob serves multiple purposes, as it adjusts the input levels, FX send levels and mon, main and phones output levels, depending on which input or output is currently selected.

NOTE The default selection is “Main & Phones”. If another button is pressed, be sure to raise or lower the level within five seconds. After five seconds of inactivity, the selection changes back to the default “Main & Phones”.

16. Feedback desTROyer

The multi-band Feedback Destroyer hunts down offending feedback frequencies and applies notch filters automatically to destroy feedback and maximize gain prior to feedback.

There are two Feedback Destroyer settings to choose from: off and on.

Off [Default] – The Feedback Destroyer is not engaged. Additionally, all filters clear when the Feedback Destroyer is turned off.

On – When the automatic Feedback Destroyer is turned on, scanning occurs continuously. The filters will engage sequentially when feedback is present and then it will be locked. If feedback is identified on an existing filter, the notch will deepen to further destroy the offending feedback frequency.

NOTE Note that the Feedback Eliminator does not “store frequencies”, so it resets every time it is turned off.

After five seconds of inactivity, the selection changes back to the default “Main & Phones”.

17. FX

Reach includes 16 “gig ready” effects, including various reverbs, delays, choruses and combinations of these, as well.

On the Reach, there are four preset effects to choose from, including Verb 1, Verb 2, Delay 1, or Delay 2. Simply press the FX button repeatedly until the FX you want illuminates green. After five seconds of inactivity, the selection changes back to the default “Main”.

Additional effects may be selected via Mackie Connect. The app also adds control over the master FX return level. More information may be found in the Mackie Connect Reference Guide.

Be sure to check out a more detailed description of each effect in Appendix C, page 24.

18. EQ Mode

Here you are able to change the Reach’s EQ mode to tailor it to best suit your particular application.

On the Reach, there are four preset modes to choose from, including PA, DJ, Soloist and Voice. Simply press the EQ button repeatedly until the EQ mode you want illuminates white.

Flat EQ Mode – This mode is full range, but focuses on mid-range clarity where vocals often reside.

DJ EQ Mode – This mode bumps the lows and highs, perfect for music playback.

Solo EQ Mode – This mode features a low frequency roll-off to get rid of unwanted thumps and adds boost and sparkle to mid-range and high frequencies. This mode is perfect for plug-and-play singer-songwriters.

Voice EQ Mode – This mode features a significant low frequency roll-off to get rid of unwanted thumps. It also adds boost and sparkle to mid-range and high frequencies. This plug-and-play mode is perfect for larger venue applications where speech is the primary audio source in need of clear and precise intelligibility.

Additionally, Reach features 3-band EQ per channel, accessible via the Mackie Connect app. More information may be found in the Mackie Connect Reference Guide.

After five seconds of inactivity, the selection changes back to the default “Main & Phones”.

Reach: Side Panel Features continued...

19. Speaker Selection [Side Button]

Here you are able to select which side monitor speakers (if any) will output sound. There are choices to choose from, but only one may be selected at a time: only the left, only the right, both or neither (mute). Simply press the side button repeatedly until the monitor(s) you want to hear, five seconds, use the Mackie Connect app!

The selected side output level may be adjusted after the mon output button [12] is pressed.

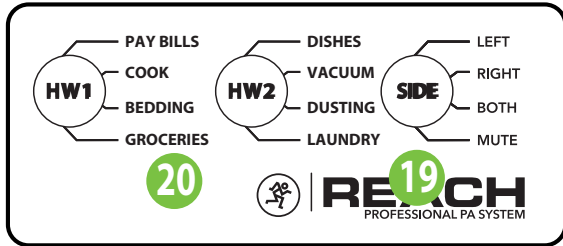

20. Chores [HW1 / HW2 Buttons]

What is “HW1” and “HW2” and what do they have to do with Reach? Well, “HW” is short for “Housework”. That’s right, your Reach Professional PA System will do your housework, leaving you plenty of time to dabble in other (much more important) activities!

Tired of doing the dishes? Don’t feel like going grocery shopping? Paying bills is not really high on your priority list? Cooking...who wants to do that after a long day grind? Reach will do all of those (and more) for you! Simply press the HW1 or HW2 button repeatedly until the chore you want Reach to do

for you illuminates white, then off you go!

NOTE While we realize that this list is far from complete, it is a start. We’re looking at adding HW3 and HW4 buttons for Reach V2.0. A few things have come up – mostly

of the kid’s “type stuff”, but if you have any suggestions, please send them to: yeahthisisjustajoke_sorry@gottadoyourownchore.com

Factory Reset [aka Vulcan Mind Meld]

Since settings may be changed via Mackie Connect, it may be necessary to reset the Reach Professional PA to its factory settings.

Please keep in mind that this erases all settings, including any levels, EQs, etc. that may have been set. Be sure to power down any amps and/or powered speakers before resetting Reach.

Simply press and hold the Mon, Channel 2 and Channel 4 buttons simultaneously to reset the Reach Professional PA to its factory settings. The LEDs flash when it has reset.



If you use the factory default key combination, you are also wiping the Reach’s memory of devices. To remedy this, on your smartphone, tablet or other Bluetooth device, you will need to ‘forget device’ in the Bluetooth settings, then re-pair in order to regain communication and functionality.

Placement



WARNING: Installation should only be done by an experienced technician. Improper installation may result in equipment damage or death. Make sure that Reach is installed in a stable and secure way in order to avoid any conditions that may be dangerous for persons or structures.

Reach is designed to be pole-mounted via the built-in socket located on the bottom. Be sure the pole is capable of supporting the weight of Reach. The SPM200 is a great option if using a subwoofer. Check to make sure that the support surface (e.g. floor, etc.) has the necessary mechanical characteristics to support the weight of Reach. When pole-mounting, be sure that the Reach is stabilized and secured from falling over or being accidentally pushed over. Failure to follow these precautions may result in damage to the equipment, personal injury, or death.

As with any powered components, protect them from moisture. Avoid installing the loudspeaker in places exposed to harsh weather conditions. If you are setting them up outdoors, make sure they are under cover if you expect rain.

Room Acoustics

Reach is designed to sound fantastic in nearly every application.

But, room acoustics play a crucial role in the overall performance of a sound system. However, the wide high-frequency dispersion of Reach helps to minimize the problems that typically arise.

Here are some additional placement tips to help overcome some typical room problems that might arise:

- Placing Reach in the corner of a room increases the low frequency output and can cause the sound to be muddy and indistinct.
- Placing Reach against a wall increases the low frequency output, though not as much as corner placement. However, this is a good way to reinforce the low frequencies, if so desired.

- Avoid placing Reach directly on a hollow stage floor. A hollow stage can resonate at certain frequencies, causing peaks and dips in the frequency response of the room. It is better to place it on a sturdy stand designed to handle the weight.
- Position Reach so the high-frequency drivers are two to four feet above ear level for the audience (making allowances for an audience that may be standing/dancing in the aisles). High frequencies are highly directional and tend to be absorbed much easier than lower frequencies. By providing direct line-of-sight from the loudspeakers to the audience, you increase the overall brightness and intelligibility of the sound system.
- Highly reverberant rooms, like many gymnasiums and auditoriums, are a nightmare for sound system intelligibility. Multiple reflections off the hard walls, ceiling, and floor play havoc with the sound. Depending on the situation, you may be able to take some steps to minimize the reflections, such as putting carpeting on the floors, closing draperies to cover large glass windows, or hanging tapestries or other materials on the walls to absorb some of the sound. However, in most cases, these remedies are not possible or practical. So what do you do? Making the sound system louder generally doesn't work because the reflections become louder, too. The best approach is to provide as much direct sound coverage to the audience as possible. The farther away you are from the speaker, the more prominent will be the reflected sound. Use more Reach Professional PA Systems strategically placed so they are closer to the back of the audience. If the distance between the front and back speakers is more than about 100 feet, you should use a delay processor to time-align the sound. (Since sound travels about 1 foot per millisecond, it takes about 1/10 of a second to travel 100 feet.) Keep in mind that the EQ mode and feedback destroyer are two great ways to compensate for some of these issues. See page 14 for more information [18, 16].

Smart Protect

There are advanced DSP protection mechanisms designed into Reach to safeguard the speakers and amplifiers from inadvertent damage.



The protection circuits are designed to protect the speakers under reasonable and sensible conditions.

Should you ignore signs [e.g. excessive distortion], you can still damage the speaker by overdriving it past the point of amplifier clipping. Such damage is beyond the scope of the warranty.

Limiting

Each driver has its own compression circuit which helps protect it from damaging transient peaks. The compressor is designed to be transparent and is not noticeable under normal operating conditions.

Overexcursion Protection

A 12 dB/octave high-pass filter just prior to the low-frequency amplifier prevents very low frequencies from being amplified. Excessive low-frequency energy can damage the woofer by causing it to “bottom out,” also known as overexcursion, which is equivalent to a mechanical form of clipping.

Thermal Protection

All amplifiers produce heat. Reach is designed to be efficient both electrically and thermally.

In the unlikely event of the amplifier overheating, a built-in thermal switch will activate, muting the signal.

When the amplifier has cooled down to a safe operating temperature, the thermal switch resets itself, and Reach resumes normal operation.

If the thermal switch activates, try turning down the level control a notch or two on the mixing console (or the back of Reach) to avoid overheating the amplifier. Be aware that direct sunlight and/or hot stage lights may be the culprit of an amplifier overheating.

AC Power

Be sure Reach is plugged into an outlet that is able to supply the correct voltage. It will continue to operate at lower voltages, but will not reach full power.

Be sure the electrical service can supply enough amperage for all the components connected to it.

We recommend that a stiff (robust) supply of AC power be used because the amplifiers place high current demands on the AC line. The more power that is available on the line, the louder the speakers will play and the more peak output power will be available for a cleaner, punchier bass. A suspected problem of “poor bass performance” is often caused by a weak AC supply to the amplifiers.



Never remove the ground pin on the power cord or any other component of Reach. This is very dangerous.

Care and Maintenance

Reach will provide many years of reliable service if you follow these guidelines:

- Avoid exposing it to moisture. If it's set up outdoors, be sure it's under cover if rain is expected.
- Avoid exposure to extreme cold (below freezing temperatures). If you must operate Reach in a cold environment, warm up the voice coils slowly by sending a low-level signal through them for about 15 minutes prior to high-power operation.
- Use a dry cloth to clean Reach. Only do this when the power is turned off. Avoid getting moisture into any of the openings.

Appendix A: Service Information

If you think your Reach has a problem, please check out the following troubleshooting tips and do your best to confirm the problem. Visit the Support section of our website (www.mackie.com/support) where you will find lots of useful information such as FAQs and other documentation. You may find the answer to the problem without having to send your Reach away.

Troubleshooting

No power

- Our favorite question: Is it plugged in? Make sure the AC outlet is live [check with a tester or lamp].
- Our next favorite question: Is the power switch on? If not, try turning it on.
- The internal AC line fuse may be blown. This is not a user serviceable part. If you suspect the AC line fuse is blown, please see the "Repair" section next.

No sound

- Is the input level control for the input source turned all the way down? Verify that all the level controls in the system are properly adjusted. Look at the level meter to ensure that the Reach is receiving a signal.
- Is the signal source working? Make sure the connecting cables are in good repair and securely connected at both ends. Make sure the output level control of the source is turned up sufficiently.
- Make sure the source(s) are not turned off or muted. If you find something like this, make sure the level is turned down before disengaging the offending switch.

Poor bass performance

- Poor bass performance may be the result of bad AC power. See the section titled 'AC Power' on the previous page for further details.

Poor sound

- Is it loud and distorted? Make sure that you're not overdriving a stage in the signal chain. Verify that all level controls are set properly.
- Is the input connector plugged completely into the jack? Be sure all connections are secure.

Noise

- Make sure all connections to the Reach are good and sound.
- Make sure none of the signal cables are routed near AC cables, power transformers, or other EMI-inducing devices.
- Is there a light dimmer or other SCR-based device on the same AC circuit as the Reach? Use an AC line filter or plug the Reach into a different AC circuit.

Hum

- Try disconnecting the cable connected to the main input jack. If the noise disappears, it could be a "ground loop," rather than a problem with the Reach. Try some of the following troubleshooting ideas:
- Use balanced connections throughout your system for the best noise rejection.
- Whenever possible, plug all the audio equipment's line cords into outlets which share a common ground. The distance between the outlets and the common ground should be as short as possible.

Bluetooth Issues

- Please email or call Technical Support if you are having Bluetooth connection issues.
 - o techmail@loudtechinc.com
 - o 1-800-898-3211

Repair

For warranty service, refer to the warranty information on page 25.

Non-warranty service for Reach is available at a factory-authorized service center. To locate the nearest service center, visit www.mackie.com/support. Service for a Reach living outside the United States can be obtained through local dealers or distributors.

If you do not have access to our website, you may call the Tech Support department at 1-800-898-3211, Monday-Friday, during normal business hours, Pacific Time, to explain the problem. Tech Support will tell you where the nearest factory-authorized service center is located in your area.

Appendix B: Technical Information

Reach

Specifications

Frequency Response (-10 dB)	50 Hz – 20 kHz
Frequency Response (-3 dB) Max	Hz – 17 kHz
peak SPL (@ 1m calculated) ¹	126 dB
Crossover Point	2.6 kHz
Dispersion	150° x 50° (H x V)

Acoustic Performance:

High Frequency Power Amplifier

Rated Power	60 watts rms 120 watts peak
Rated THD	10%
Cooling	Convection
Design	Class D

Side Fill Power Amplifier

Rated Power	2x 50 watts rms 2x 100 watts peak
Rated THD	10%
Cooling	Convection
Design	Class D

High-Frequency Section

Tweeter Array:

Voice Coil / Horn Entry	3x 1.0 in / 25 mm Polyethylene
Diameter	Diaphragm Material
	Naphthalate (PEN) Ferrite
Magnet Material	

Full Range Side Fills:

Woofers	2x 4.0 in / 102 mm
Diameter	Voice
	1.0 in / 25 mm Pulp
Coil Diameter	Composite Ferrite
Diaphragm	
Material	Magnet
Material	

System Processing

Channel EQ	3-band
Main EQ	4 voicing modes
FX	16 presets
Feedback	On / Off
Destroyer	

Low-Frequency Section

Woofers Diameter	2x 6.5 in / 165 mm
Voice Coil Diameter	1.3 in / 33 mm Pulp
Diaphragm	Composite Ferrite
Material	Magnet
Material	

Equalization

Low Shelving	±12 dB @ 80 Hz
Mid-Peaking	±12 dB @ 2.5 kHz
High Shelving	±12 dB @ 5 kHz
Increments	±3 dB

Power Amplifiers

System Power Amplification	
Rated Power	360 watts rms 720 watts peak
Low Frequency Power Amplifier	
Rated Power	2x 100 watts rms 2x 200 watts peak
Rated THD	10%
Cooling	Convection
Design	Class D

Input / Output

XLR	10 kΩ balanced
1/4" TRS	>100 kΩ balanced
1/4" TS	>400 kΩ unbalanced
1/8"	10 kΩ
Link In	10 kΩ
Link Out	100 Ω
Headphone Out	10 Ω

¹ Calculated from driver sensitivity and amplifier power.

Reach Specifications

continued... Power

Line cord	100 – 120 V~, 50 – 60 Hz, 100W 200 – 240 V~, 50 – 60 Hz, 100W
Operating Temperature [extended ambient temperature]	0 to 40 °C 32 to 104 °F

Safety Features

Input Protection	Peak and RMS limiting, power supply and amplifier thermal protection
Display LEDs	Defeatable front power ON, Rear OL (Overload)
Status Info	Input and output levels, FX on/off and level, Feedback Destroyer on/ off, EQ speaker voicing on/ off

Bluetooth Information

Bluetooth Protocol	3.0
Bluetooth Function	Audio Streaming and User Interface Control

Construction Features

Cabinet	PC-ABS
Finish	High durability black paint
Handles	One on top, one in back
Grille	Powder-coated 18 gauge steel

Physical Properties

Height	28.0 in / 711 mm
Width	8.6 in / 218 mm
Depth	9.5 in / 241 mm
Weight	31.4 lb / 14.2 kg

Options

Reach Bag	P/N 2036809-31
-----------	----------------

Disclaimer

Since we are always striving to make our products better by incorporating new and improved materials, components, and manufacturing methods, we reserve the right to change these specifications at any time without notice. The "Running Man" figure is a registered trademark of LOUD Technologies Inc.

All other brand names mentioned are trademarks or registered trademarks of their respective holders, and are hereby acknowledged.

©2015 LOUD Technologies Inc.
All Rights Reserved.

Reach Dimensions

WEIGHT
31.4 lb
14.2 kg

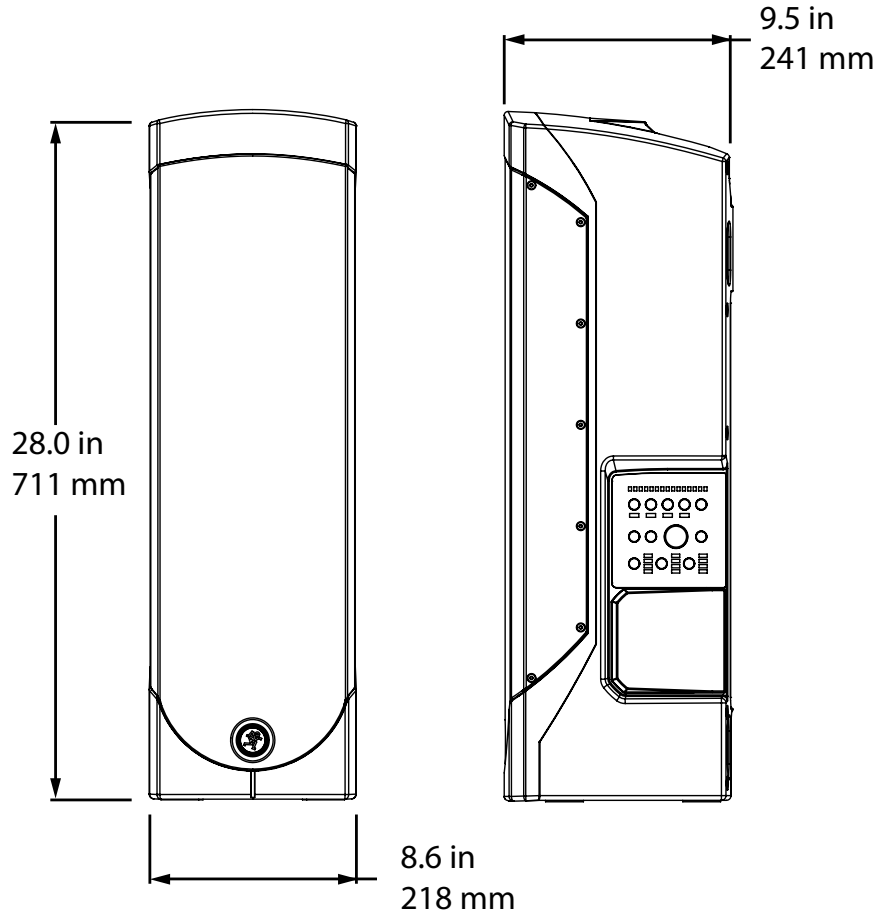
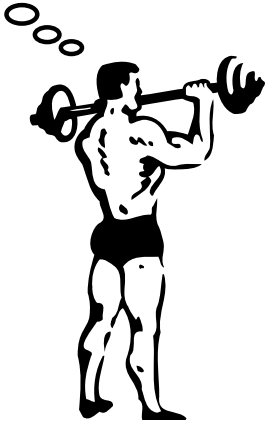

Reach Frequency Response Legend

Flat Speaker Mode – This mode is full range, but focuses on mid-range clarity where vocals often reside.

Solo Speaker Mode – This mode features a low frequency roll-off to get rid of unwanted thumps and adds boost and sparkle to mid-range and high frequencies. This mode is perfect for plug-and-play singer-songwriters.

DJ Speaker Mode – This mode bumps the lows and highs, perfect for music playback.

Voice Speaker Mode – This mode features a significant low frequency roll-off to get rid of unwanted thumps. It also adds boost and sparkle to mid-range and high frequencies, critical for speech applications. This plug-and-play mode is perfect for larger venue applications where speech is the primary audio source in need of clear and precise intelligibility.

Reach Frequency Response

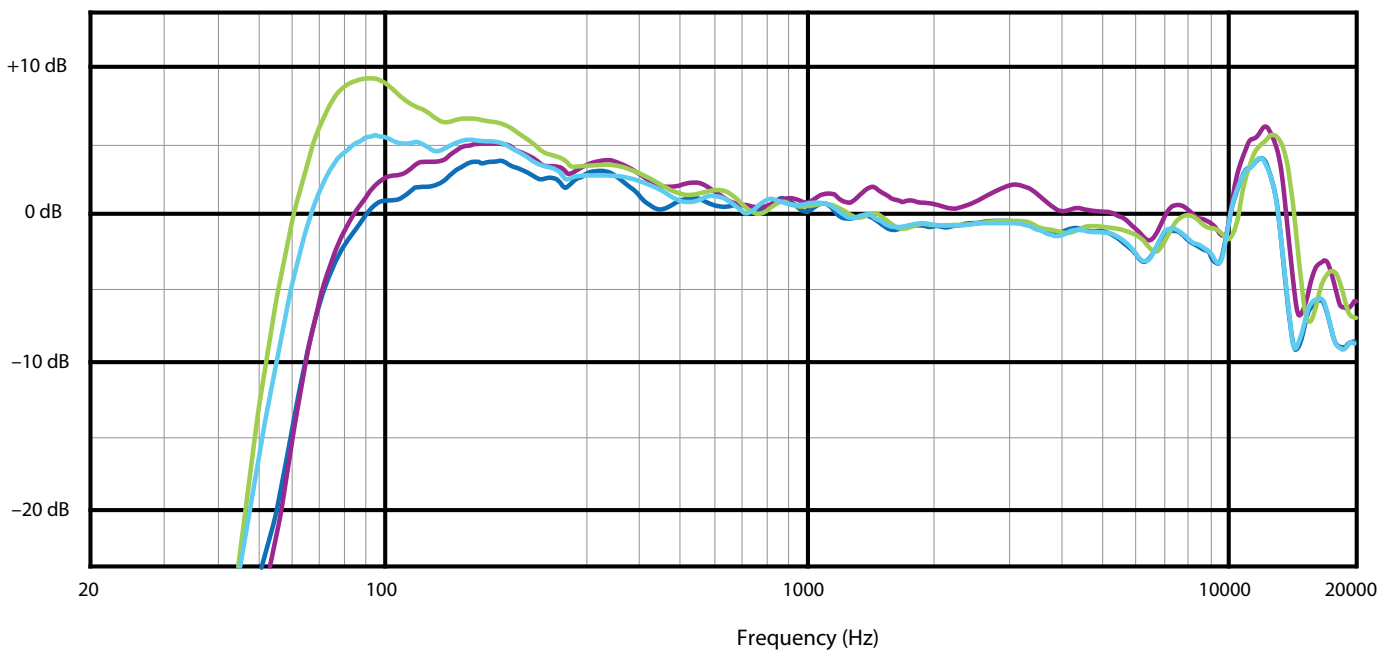

Reach Block Diagram

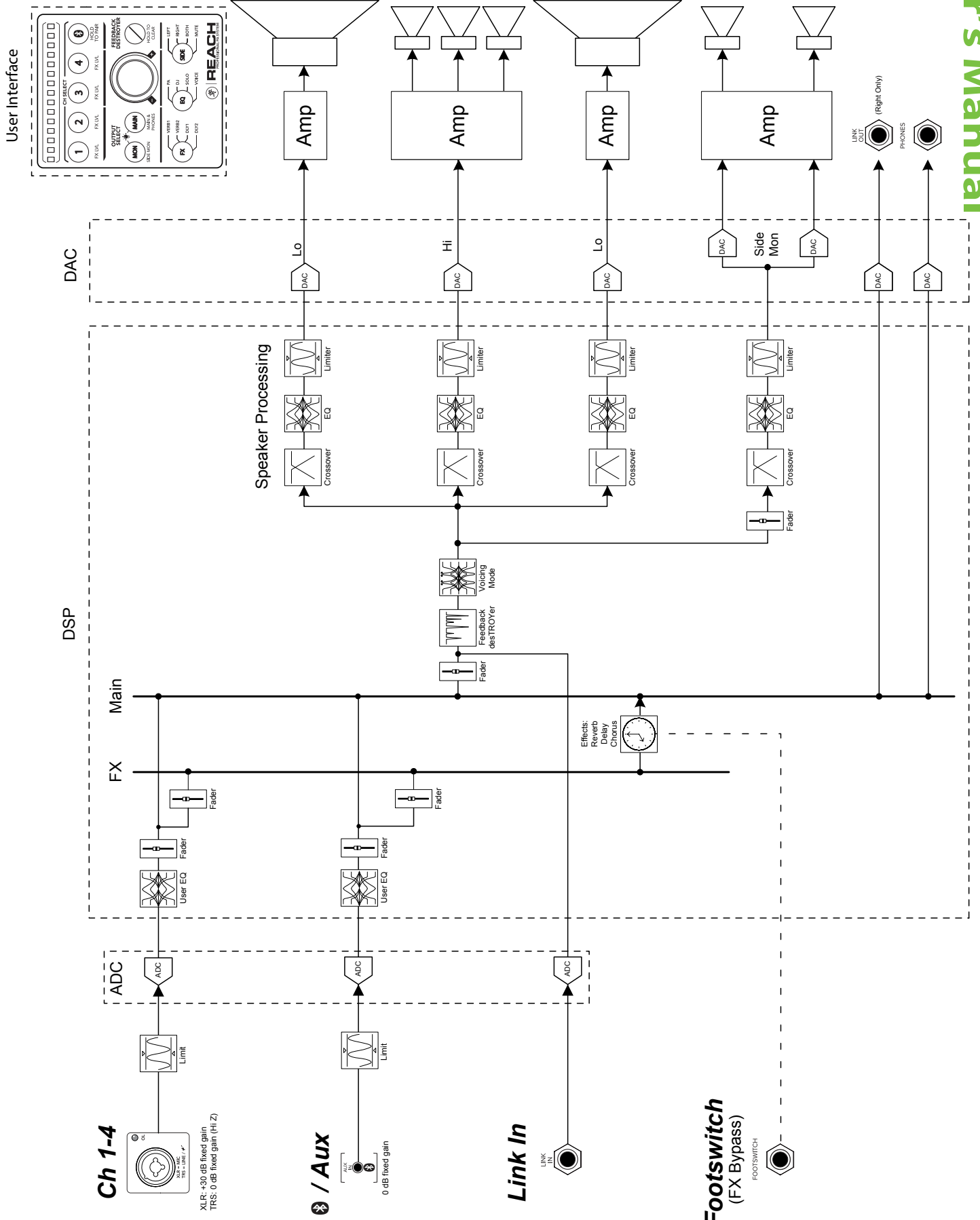

Appendix C: Table of Effects Presets

All FX listed below may be accessed via the Mackie Connect App. Descriptions and examples of the four FX that are accessed via Reach [Verb 1, Verb 2, Delay 1 and Delay 2] are noted in the *Title* column.

No FX on Reach will illuminate when an FX is selected via the Mackie Connect App.

Title	Description	Example of its use
Bright Room	This room has a bright tone with lots of scattered reflections to simulate harder, more reflective surfaces.	Useful on vocals that require a brighter reverb to cut through the mix, or for giving acoustic instruments a livelier vibe.
Warm Lounge	This preset features a medium sized room sound, with just enough enhancement of the lower mids to produce a warm tone.	Useful for vocals on songs that require a larger, more “wet” sound, or for giving dimension to bright horns without adding harshness.
Small Stage	This preset simulates the sound of a small concert stage, with a medium reverb time and reverberant space.	Useful for vocals or guitars in fast paced, high-energy songs that call for a “live” sounding reverberation.
Warm Theater [Verb 2 on Reach]	This reverb has a warm bodied tone and medium long reverb time to simulate the live acoustics of a theater space.	Perfect for vocals, drums, acoustic and electric guitars, keyboards and more.
Warm Hall	This reverb simulates the sound of a spacious, yet cozy, heavily draped and carpeted concert hall with an especially warm tone.	Perfect for adding natural concert hall ambience to close-mic’ed orchestral instruments.
Concert Hall	This hall reverb is characterized by its large, spacious sound, long pre-delay, and vibrant tone.	Adds life to acoustic instruments and vocals from solos to full-on symphonies and choirs.
Plate Reverb [Verb 1 on Reach]	This preset emulates vintage mechanical reverberation that was generated with a metal plate. Its sound is characterized by lots of early reflections and no pre-delay.	Perfect for thickening percussive instruments, such as a snare drum, or tight vocal arrangements.
Cathedral	This reverb emulates the extremely long tails, dense diffusion and long pre-delays and reflections that would be found in a very large, stone walled house of worship.	Gives amazing depth to choirs, wind instruments, organs and soft acoustic guitars.
Chorus	This preset provides a soft, ethereal sweeping effect that is useful for thickening and for making a particular sound pop out of the mix.	Perfect for enhancement of electric and acoustic guitar and bass, or to add a dramatic effect to vocals, particularly group harmonies and choirs.
Chorus + Reverb	This preset perfectly combines the chorus effect above with a large, roomy reverb.	This effect thickens the sound with chorus while adding warmth and spaciousness thanks to the smooth reverb.
Doubler	This effect simulates the sound of a vocal or instrument being recorded twice (double-tracked) on a multi-track recorder.	Provides a vibe that is similar to chorus without the subtle swirl.
Tape Slap [Delay 1 on Reach]	This effect provides a single, relatively rapid delay of the original signal, with the added warmth that vintage tape-based echo units provided.	Often used on vocals for a 1950’s era feel, or on guitars for a surf-type tone. Often used by people whose favorite number is 13.
Delay 1 [Delay 2 on Reach]	This preset provides 300 ms delay. The smaller the delay time, the faster the delay.	This FX works best with full, up-beat music like rock where the delay needs to cut through the mix.
Delay 2	This preset provides 380 ms delay. The smaller the delay time, the faster the delay.	This FX works best with full, up-beat music like rock where the delay needs to cut through the mix.
Delay 3	This preset provides 480 ms delay. The smaller the delay time, the faster the delay.	This FX works best with full, up-beat music like rock where the delay needs to cut through the mix.
Reverb + Delay	This effect combines the Warm Theater reverb effect with the echoes of the 3-repeat delay effect.	Perfect for thickening vocals while adding dimensions, it can also be used as a spacey effect on electric guitars.

Limited Warranty

Please keep your sales receipt in a safe place.

This Limited Product Warranty ("Product Warranty") is provided by LOUD Technologies Inc. ("LOUD") and is applicable to products purchased in the United States or Canada through a LOUD-authorized reseller or dealer. The Product Warranty will not extend to anyone other than the original purchaser of the product (hereinafter, "Customer," "you" or "your").

For products purchased outside the U.S. or Canada, please visit www.mackie.com/support to find contact information for your local distributor, and information on any warranty coverage provided by the distributor in your local market.

LOUD warrants to Customer that the product will be free from defects in materials and workmanship under normal use during the Warranty Period. If the product fails to conform to the warranty then LOUD or its authorized service representative will at its option, either repair or replace any such nonconforming product, provided that Customer gives notice of the noncompliance within the Warranty Period to the Company at: www.mackie.com/support or by calling LOUD technical support at 1.800.898.3211 (toll-free in the U.S. and Canada) during normal business hours Pacific Time, excluding weekends or LOUD holidays. Please retain the original dated sales receipt as evidence of the date of purchase. You will need it to obtain any warranty service.

For full terms and conditions, as well as the specific duration of the Warranty for this product, please visit www.mackie.com/support.

The Product Warranty, together with your invoice or receipt, and the terms and conditions located at www.mackie.com/support constitutes the entire agreement, and supersedes any and all prior agreements between LOUD and Customer related to the subject matter hereof. No amendment, modification or waiver of any of the provisions of this Product Warranty will be valid unless set forth in a written instrument signed by the party to be bound thereby.

Need help with Reach?

- Visit www.mackie.com/support to find FAQs, manuals, addendums, and other documents.
- Email us at: techmail@loudtechinc.com.
- Telephone 1-800-898-3211 to speak with one of our splendid technical support chaps (Monday through Friday, normal business hours, Pacific Time).

This page left blank intentionally

This page left blank intentionally



16220 Wood-Red Road NE
Woodinville, WA 98072 • USA
Phone: 425.487.4333
Toll-free: 800.898.3211
Fax: 425.487.4337
www.mackie.com
